

Performance Analysis of the Operation of the Three-Phase Power Relay RM3-TR113QN by Approach Based On Mathematical Morphology

¹Pembesuka Nepa-Nepa Laurent,¹Kabongo Ntambwe Georges ,
^{1*}Banza Wa Banza Bonaventure

¹School of Industrial Engineering, University of Lubumbashi, PO. Box 1825 Lubumbashi, DR Congo

*Corresponding author: banzaviola2007@yahoo.fr

Abstract:

The RM3-TR113QN7 relay is a multifunction device designed to monitor the presence and direction of phase rotation in three-phase power, as well as overvoltage ($U > U_n$) or under voltage ($U < U_n$). The complete operation of this device is explained by the mathematical expressions of different cases of three-phase power supply occurring on a three-phase power supply. We used this relay to protect industrial power supplies on three phases (400 VAC three-phase 50Hz). The case study here is the AMATO-FRERES Company in Lubumbashi, DR Congo. In other scenarios, the device responds correctly, but there were three scenarios for which the relay did not detect faults, even the user manual does not specify them. This is relative to: 10% overvoltage on phase L1, simultaneous overvoltage of 10% on the L1 and L2 phases and simultaneous voltage of 10% on phases L2 and L3. That is why we made observations and calculations to take stock of this gap.

Keywords: Performance, Phase failure, overvoltage, under-voltage, incorrect rotational direction of phases.

1. Introduction

In order to insure controls of three-phase supply Electric-Schneider manufacturer made the RM3-TR113QN7 relay that is multifunction. This relay insures (Schneider, 1996): detection of phase failure, detection of under voltage (exceeding 10%), detection of overvoltage (exceeding 10%) and detection of rotational direction fault of phases in a 400V three-phase supply (Suryanarayana et al., 2019; Wang et al., 2019). Although the relay is made in order to detect 400 volts three-phase supply faults, testing the relay on a supply circuit to verify all multiple functions, we notice that the relay did not detect:

- Overvoltage of 10% occurred only on the phase L1;
- Simultaneous 10% over voltage occurred on phases L1 and L2;
- Simultaneous 10% under voltage occurred on phases L2 and L3.

This work answers the following question:

- What explains the failure of the relay with respect to the three cases, while in the twenty-one other cases, the relay responds correctly?

To answer this question, the following actions were performed:

- Obtain the relay electronic card (control circuit board 4 450 310 00 4);
- Establish the circuit diagram of the RM3-TR113QN7 relay;
- Do the study of the diagram;
- Reveal mathematical expressions describing the function of the relay - compared to the measurement of the amplitude of the rectified sinusoidal signal;
- Explain the detection of 21 faults in a three-phase power supply;
- Finally explain why the device did not detect the three cases of default mentioned above.

Thus, we establish the circuit diagram and, depending on the type of fault, explanations will be given on how each fault is detected, on how the relay provides protection for the three-phase installation. How protection is provided by electronic components such as LM224 operational amplifiers, HCF4011 and HCF4001 logic gates, and HCF4541 programmable timer, using mathematical expressions. For this, we use the theory of rectifier circuits for power supplies, in particular the calculation of the average voltage of the rectified sinusoidal signals, the amplification gain of a non-inverse diagram of an operational amplifier (OAP). On a 3-phase power supply, 24 faults are possible to occur. For the 24 faults analyzed; three faults are non-detected. Mathematical expressions and values given in summary of table presented in this document give us explanations of the matter (Kavaskar&Mohanty, 2017).

The three cases of faults are:

- Overvoltage of 10% only on the phase L1.

- Simultaneous overvoltage of 10% on L1 and L2.
- Simultaneous Under voltage of 10 % on L2 and L3.

2. Methodology

We proceeded to the disassembly of the relay and obtained the printed circuit board of the relay (printed control board 4 450 310 00 4), we managed to draw the circuit diagram of the relay RM3-TR113QN7 and developed the electrical diagram of operation to understand how the detection of defects is carried out (Figure 1):

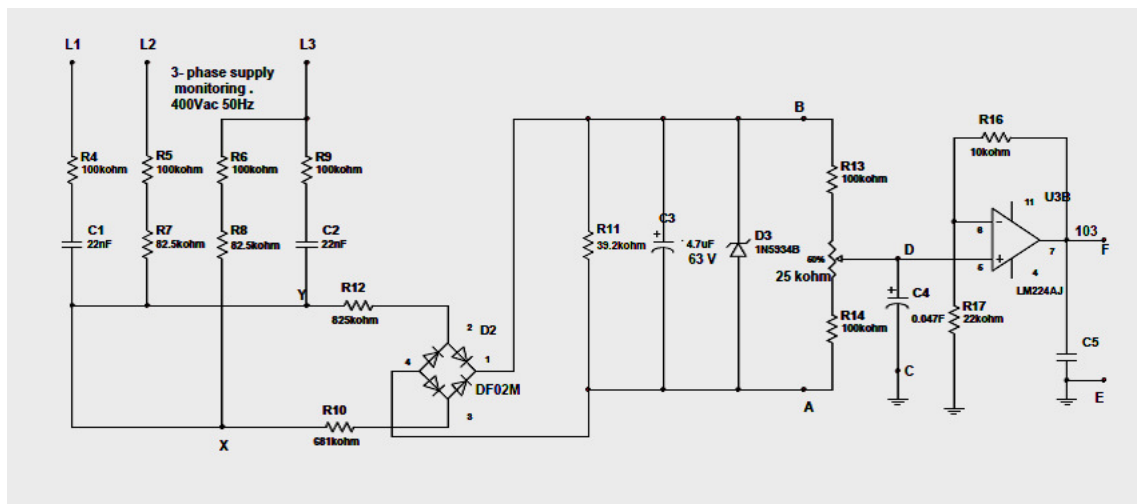

Figure 1-Detection circuit diagram of the relay RM3-TR113QN7, for detection of 3-phase supply faults.

From the average value calculations of the forward voltage and RMS values of rectified sinusoidal signals delivered by electronic switches, from amplification gain calculations according to the theory of the comparator mode and the comparator mode operational amplifiers and follower mode (Kenneth, 2007; Deekshit et al., 2018).

The relay has in its manufacture:

- a rectifier bridge DF02M for the relay power supply circuit, followed by a voltage regulator LM317 from which different reference voltages are produced to be applied to the reference input pins of the comparators. A DF02M rectifier bridge for the relay measurement circuit, from which different reference voltages are produced to be applied to the signal input pins of the comparators, and then to detect power supply faults.

- "Quadruple Operational Amplifier LM224" integrated circuit, associated with the "Quad NOR-Gate HCF4001", "Quad NAND Gate HCF4011" and "Timer HCF4541", all ensuring the detection and switching of the relay.

Since the RM3-TR113QN7 relay is powered by a normal three-phase voltage, we measured the voltage values on the pins of the LM317, LM224 components and compared them to the actual values calculated and summarized. The Excel 2010 and Microsoft Encarta Maths software were used respectively for the calculation tables and for drawing sinusoidal graphs (Ahmad et al., 2011; Chaitanya & Yadav, 2018).

3. Results and Discussion

3.1. Calculation of the average voltage of the rectified signal

When the diodes D1 and D2 are forward, while the diodes D3 and D4 are inverted or reversed, figure 2 may be in the following equivalent form where u_{xy} is the instantaneous voltage (Figure 3).

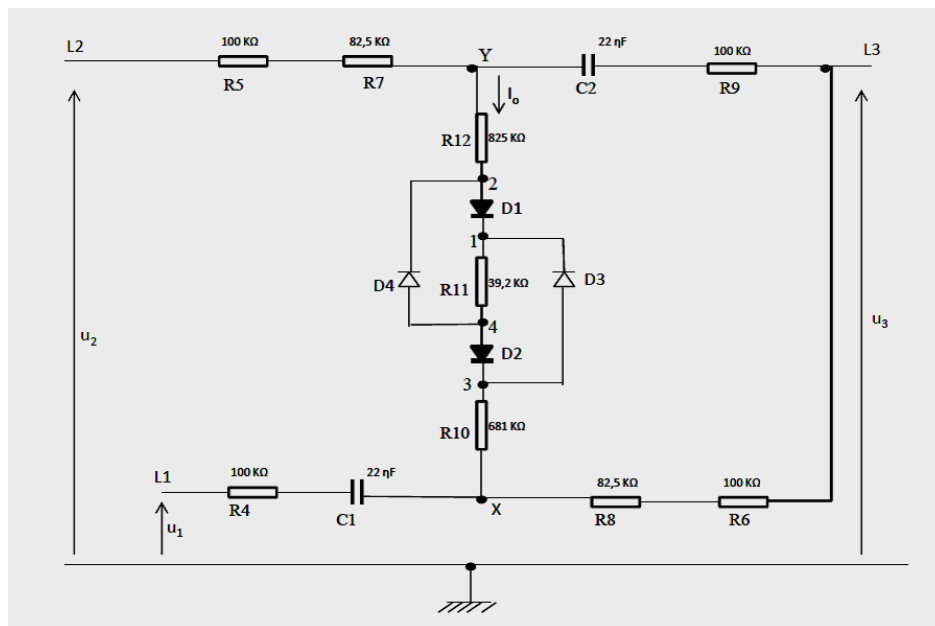

Figure 2- Stage of circuit rectifier of the relay.

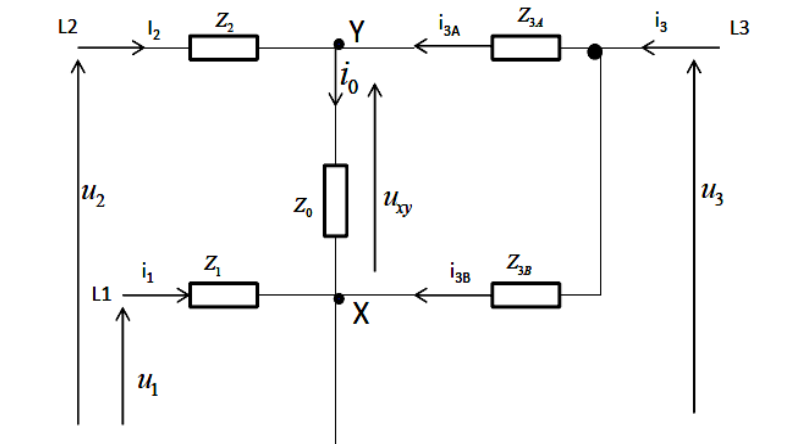

Figure 3-Equivalent diagram of rectifier stage. The resistor R_4 and capacitor C_1 of figure 2 are represented by the equivalent impedance Z_1 . The resistors R_5 and R_7 of figure 2 are represented by the equivalent impedance Z_2 . The resistor R_9 and capacitor C_2 of figure 2, are represented by the equivalent impedance Z_{3A} . The resistors R_8 and R_6 of figure 2 are represented by the equivalent impedance Z_{3B} on figure 3. When diodes D_1 and D_2 are forwards (D_3 and D_4 reverses), the resistors R_{10} , R_{11} , R_{12} being in series, their equivalent impedance is represented by Z_0 .

In order to determine currents in branches Calculations give for impedances:

$$Z_1 = 10^5 + 1/(j2\pi f.2210^{-9}) = 10^5(1 - 1.4476j) \quad [\Omega]$$

$$Z_2 = 10^5 + 82.510^3 = 10^5(1.825) \quad [\Omega]$$

$$Z_{3A} = 10^5 + 1/(j2\pi f.22.10^{-9}) = 10^5(1 - 1.4476j) \quad [\Omega]$$

$$Z_{3B} = 10^5 + 82.5.10^3 = 10^5(1.825) \quad [\Omega]$$

$$Z_0 = (825 + 39.2 + 681).10^3 = 10^5(15.452) \quad [\Omega]$$

Moreover: $I_2 + I_{3A} = I_0$ and $I_1 + I_{3B} = -I_0$, in other way, taking electric potential of point Y as reference potential:

$$\frac{u_3 - u_{xy}}{10^5(1 - 1.4476j)} + \frac{u_2 - u_{xy}}{10^5(1.825)} = \frac{u_{xy}}{10^5(15.452)} \quad (1)$$

$$\frac{u_1}{10^5(1 - 1.4476j)} + \frac{u_3}{10^5(1.825)} = \frac{-u_{xy}}{10^5(15.452)} \quad (2)$$

From system of equations (1) and (2), we find :

$$u_{XY} = \frac{(5,1556 + 2,6419j)u_1}{10,0762} + \frac{(4,9205 - 2,6419j)u_2}{10,0762} + u_3$$

Or : $u_{XY} = 0.5749U_{1max}(27.1321^\circ) + 0.5543U_{2max}(-28.2321^\circ) + U_{3max}(0^\circ)$

We can deduce the expression of instantaneous voltage u_{AB} on resistor R_{11} (figure 2) accordingly to the equivalent diagram bellow:

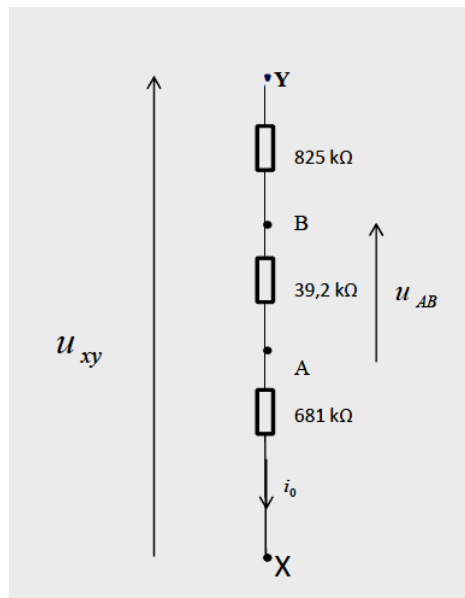

Figure 4-Equivalent diagram for calculating the value of voltage u_{AB} .

Average voltage of the rectified signal V_{ABave}

When diodes D1 and D2 are forwards while diodes D3 and D4 are reverses or contrary,

The voltage u_{AB} is a rectified sinusoidal signal!

We notice that for the sinusoidal signal $u(x) = U_{max}Sin(x)$ when he is rectified, his equation is the absolute instantaneous value of signal $u(x)$ for $\forall x \in [0, 2\pi]$.

It means: $u(x)_{rectified} = |U_{max}Sin(x)|$, for: $x \in [0, 2\pi]$.

Thus:

$$u_{AB} = \left| \frac{0,392 \cdot 10^5 \cdot u_{XY}}{15,452 \cdot 10^5} \right| = |0,0254 \cdot u_{XY}|$$

$$u_{AB} = |0.014U_1 \max(27.1321^\circ) + 0.014U_2 \max(-28.2321^\circ) + 0.0254U_3 \max(0^\circ)|$$

The voltage $u_{AB}(t)$ is a single phase sinusoidal signal rectified of period π :

In the interval $[0, \pi]$:

$$u_{AB}(t) = |0,0206U_1 \text{rms} \cdot \sin(100\pi t + 0.1507\pi + \psi_1) + 0.0199U_2 \text{rms} \cdot \sin(100\pi t - 0.1568\pi + \psi_2) + 0.0359U_3 \text{rms} \cdot \sin(100\pi t + \psi_3)|$$

The direct resistors of diodes D_1 , D_2 , D_3 and D_4 are negligible in comparison with resistors 39.2k Ω , 825 k Ω and 681 k Ω .

The value of the average voltage of the rectified signal between points A and B is given by:

$$V_{AB \text{ ave}} = \frac{2\sqrt{2}}{\pi} \cdot V_{AB \text{ rms}} = (0.901) \cdot V_{AB \text{ rms}}$$

With $V_{AB \text{ rms}}$: the value of the RMS voltage of variable signal $u_{AB}(t)$. It is sufficient to calculate $V_{AB \text{ rms}}$ in order to deduce the value of $V_{AB \text{ ave}}$.

The period of rectified signal is π .

$$V_{AB \text{ rms}}^2 = \frac{1}{T} \int_0^T u_{AB}^2(t) dt$$

$$\begin{aligned} V_{AB \text{ eff}}^2 &= (0.000212)U_1^2 \text{rms} + (0.000198)U_2^2 \text{rms} + (0.000644)U_3^2 \text{rms} \\ &+ (0.000410)U_1 \text{rms} \cdot U_2 \text{rms} \cdot \cos(\varphi_1 - \varphi_2 + 0.3075\pi) \\ &+ (0.000740)U_1 \text{rms} \cdot U_3 \text{eff} \cdot \cos(\varphi_1 - \varphi_3 + 0.1507\pi) \\ &+ (0.000714)U_2 \text{rms} \cdot U_3 \text{eff} \cdot \cos(\varphi_2 - \varphi_3 - 0.1568\pi) \end{aligned}$$

$$V_{AB \text{ ave}} = \frac{2\sqrt{2}}{\pi} \cdot V_{AB \text{ rms}} = (0.901) \cdot V_{AB \text{ rms}}$$

Thus :

$$\begin{aligned} V_{AB \text{ ave}} &= (0.901) \sqrt{[(0.000212)U_1^2 \text{rms} + (0.000198)U_2^2 \text{rms} + (0.000644)U_3^2 \text{rms} \\ &+ (0.000410)U_1 \text{rms} \cdot U_2 \text{rms} \cdot \cos(\varphi_1 - \varphi_2 + 0.3075\pi) \\ &+ (0.000740)U_1 \text{rms} \cdot U_3 \text{rms} \cdot \cos(\varphi_1 - \varphi_3 + 0.1507\pi) \\ &+ (0.000714)U_2 \text{rms} \cdot U_3 \text{rms} \cdot \cos(\varphi_2 - \varphi_3 - 0.1568\pi)]} \end{aligned}$$

Figure 6-Diagram of detection circuit of the RM3-TR113QN7 relay for detecting the faults of a 3-phase power supply.

The voltage $V_{AB\text{ave}}$, after it has been stabilized, it is then applied to the non-inverting input (Pin 5) of the operational amplifier U_{3B} (LM224) through a voltage divider bridge (Figure 7).

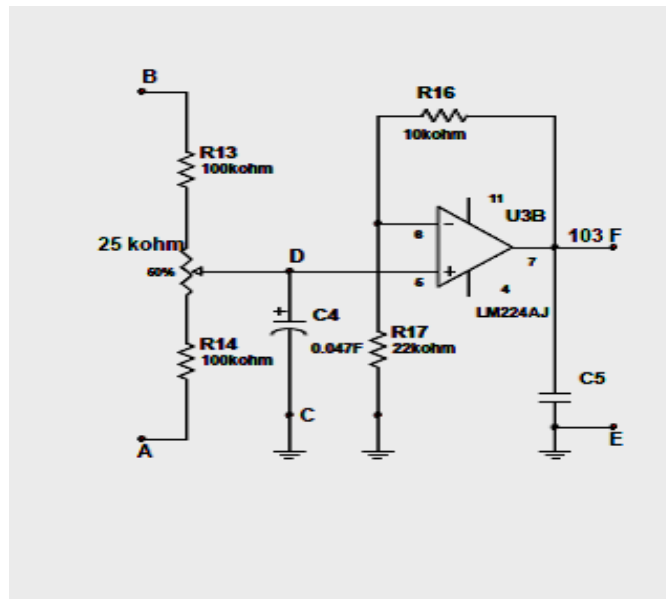

Figure 7-Operational amplifier LM224 in non-inverting input schematic.

The potentiometer with 25 kΩ maximum resistor is set at the point that the total resistance in parallel with the filter capacitor C_4 reaches 112.85 kΩ.

The voltage magnitude between pin 5 of the amplifier (LM224) and ground is given by the expression below:

$$U_{CD} = V_{AB\text{ moy}} \times \frac{(100 + 12.85)}{225}$$

The amplifier is in the schematic mode that gives the gain as follows:

$$G = 1 + \frac{Z_1}{Z_2}$$

With $Z_1 = 22\text{ k}\Omega$ and $Z_2 = 10\text{ k}\Omega$ we get: $G = 1.452$

$$\text{And then : } V_{EF} = 1.452 \times U_{CD} = V_{AB \text{ ave}} \times 1.452 \times \frac{(100+12.85)}{225}$$

Reference voltages

Figures 8A and 8B respectively show the global diagrams folio 1 and 2 of relay RM3-TR113QN7.

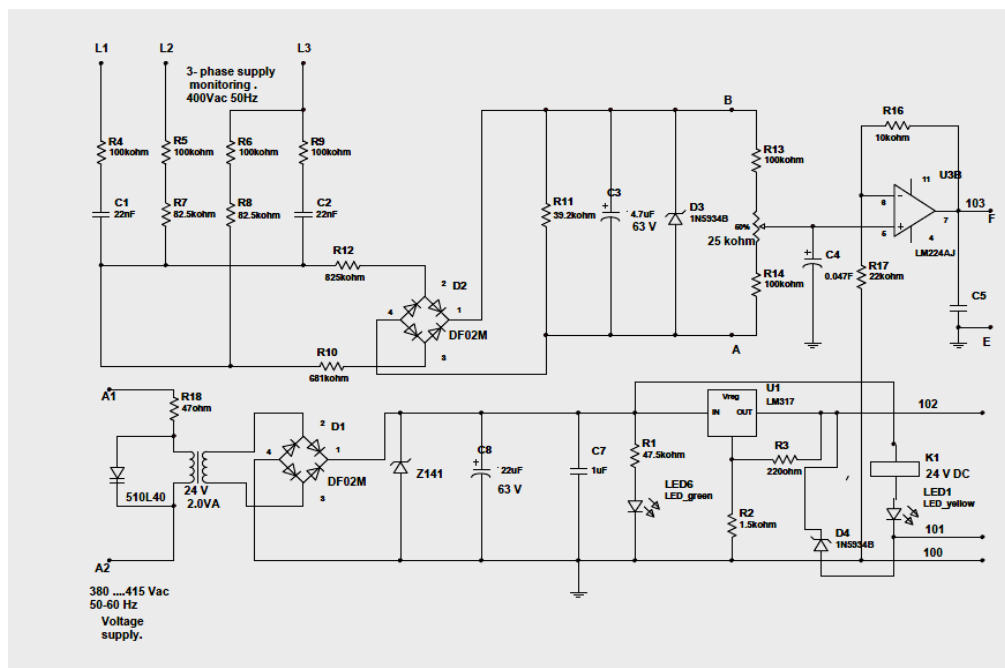

Figure 8A-Global diagram Folio 1 of relay RM3-TR113QN7.

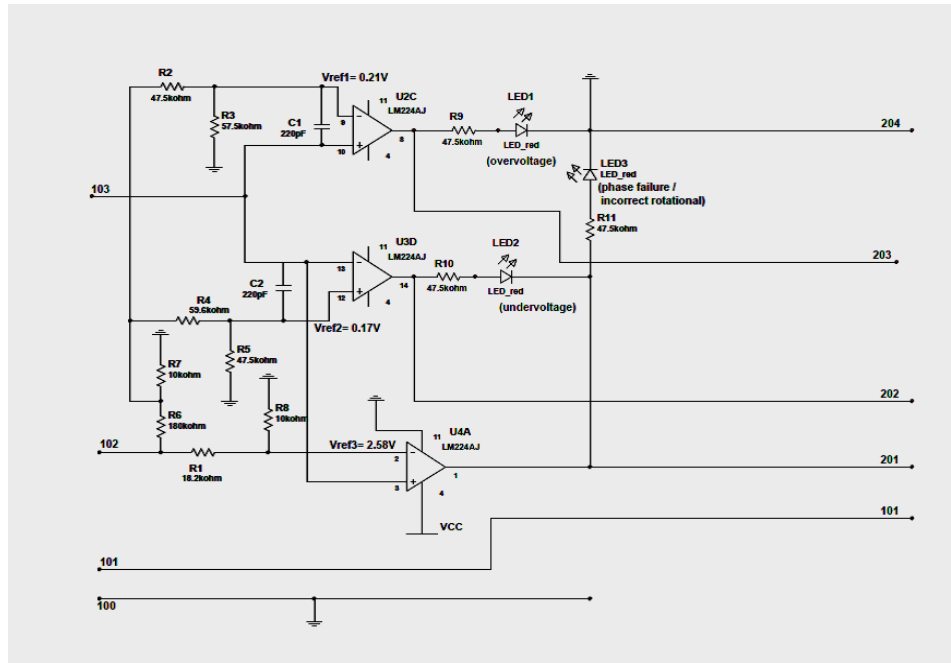

Figure 8B- Global diagram folio 2 of relay RM3-TR113QN7.

The reference voltages applied on operational amplifiers U2C (LM224), U3D (LM224), U4A (LM224) are picked from the output of the voltage regulator LM317 that delivers 7 volts.

Potentials are applied on amplifiers as follow:

- + 0.170 V applied on pin 9 of Amplifier U2C,
- + 0.140 V applied on pin 12 of Amplifier U3D,
- + 2.580 V applied on pin 2 of Amplifier U4A,

The operational Amplifier U2C ensures the detection of *overvoltage*. The operational amplifier U3D ensures the detection of *under voltage*; While Amplifier U4A ensures the detection of rotational faults of phases.

Graph of the magnitude of signal $u_{AB}(t)$ for (Figure 9): $U_{1\text{rms}} = 230\text{ V}$; $U_{2\text{rms}} = 230\text{ V}$; $U_{3\text{rms}} = 230\text{ V}$; $\varphi_1 = 0^\circ$; $\varphi_2 = 0.6667\pi$ radian; $\varphi_3 = 1.3333\pi$

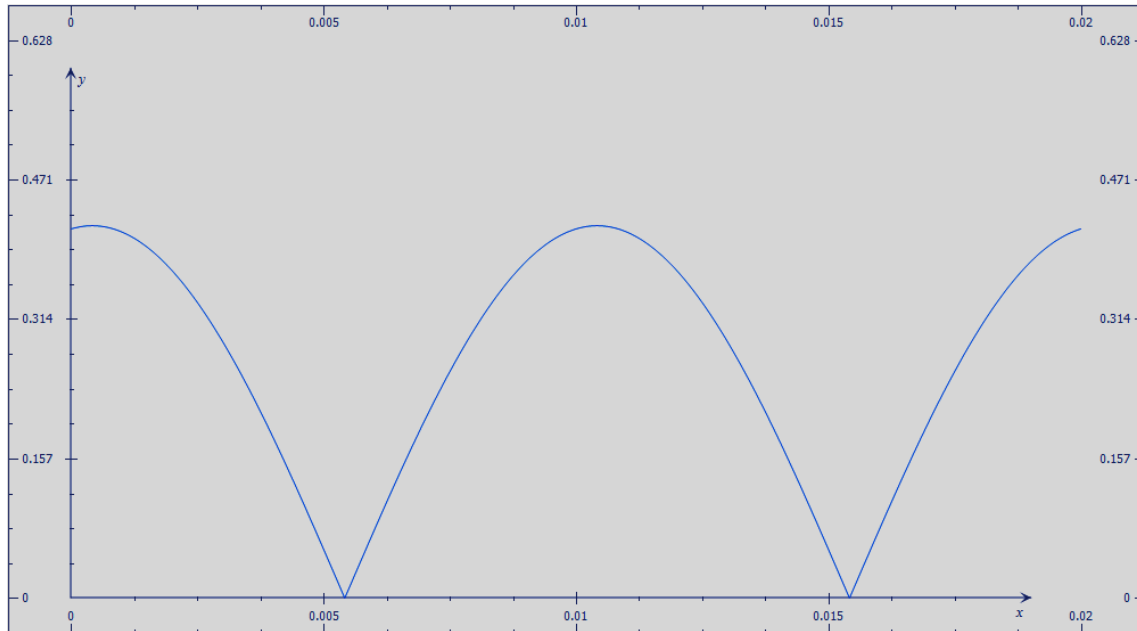

Figure 9- Graph of rectified signal u_{AB} (Source: authors graph obtained by the software Microsoft Encarta Maths).

By Calculations using software Excel, we get the summary in table 1.

Table 1- Summary of voltages values V_{ABmoy} and V_{EF} calculated for different cases of normal functioning and abnormal functioning of the 3-phase supply power.

STATE OF THE 3-PHASE POWER SUPPLY	$V_{AB\ ave}[V]$	$V_{EF}[V]$	Fault N°
NORMAL : Phase-Neutral : $U_n=230$ volts ; Frequency 50 Hz	0.21317	0.155245	
Succession of phases: L_1, L_2, L_3 .			
INVERSION OF PHASES :			
L_1 and L_2	5.017012	3.653683	1
L_1 and L_3	5.017012	3.653683	2
L_2 and L_3	5.017011	3.653683	3
PHASE FAILURE :			
L_1	3.176903	2.313607	4
L_2	3.173389	2.311048	5

	L ₃	5.014538	3.651881	6
	L ₁ and L ₂	5.258908	3.82985	7
	L ₁ and L ₃	2.915985	2.12359	8
	L ₂ and L ₃	3.017314	2.19739	9
OVERVOLTAGE :				
	> 10% on L ₁	0.205368	0.14956	10
	> 10% on L ₂	0.147398	0.1073444	11
	> 10% on L ₃	0.76	0.55348	12
	> 10% on L ₁ and L ₂	0.224480	0.1634795	13
	> 10% on L ₁ and L ₃	0.554467	0.4038	14
	> 10% on L ₂ and L ₃	0.499767	0.36396	15
	> 10% on all phases	0.23449	0.170769	16
UNDER VOLTAGE :				
	> 10% on L ₁	0.480409	0.34986	17
	> 10% on L ₂	0.531668	0.38719	18
	> 10% on L ₃	0.257697	0.18767	19
	> 10% on L ₁ and L ₂	0.737161	0.53684	20
	> 10% on L ₁ and L ₃	0.123047	0.08961	21
	> 10% on L ₂ and L ₃	0.207298	0.15097	22
	> 10% on all phases	0.191856	0.13972	23
	ROTATIONAL PHASE FAULT	0.709959	0.51703	24

The normal state of the 3-phase power supply is represented by the value of V_{EF} such as: $0.140V < V_{EF} < 0.170V$. If V_{EF} as a value less than 0.140 volts or more than 0.170 volts, it means that the 3-phase power supply is abnormal.

For all cases of fault summarized in the table 1 above:

When the 3-phase power supply is normal, that is less than 10 % overvoltage or under voltage, with normal rotational order of phases ($L_1 \rightarrow L_2 \rightarrow L_3$): the value of voltage V_{EF} is included in the interval 0.140 to 0.170 volt.

For abnormal events, the voltage V_{EF} must have a value non-included in the interval [0.140; 0170] volt.

But three events of faults make exception to be detected and this present the deficiency of the relay, even the specifications of the relay in the user manual don't point out these deficiencies. They are as follows: overvoltage more than 10% on L_1 (Fault N_0 10), overvoltage more than 10% on L_1 and L_2 . (Fault N_0 13) and under voltage more than 10% on L_2 and L_3 (Fault N_0 22).

The reason of this is that the vector of voltage V_{EF} is dependent on variable modules of simple's sinusoidal voltages L_1 , L_2 , L_3 and their angular at origin. By these concomitant variables, the average value of V_{EF} become accidentally in the interval [0.140 ; 0170] V instead of out of this interval. To get around this difficulty, it will be sufficient to introduce in the circuit a phasor of little magnitude in the line of phase L_1 in order to make compensation and correct the offset of value V_{EF} as well as this value become between the interval [0.140 ; 0170] volt. Sure enough by simulating with software Excel, when the sinusoidal signal L_1 is introduced with a phase shifting ψ_1 equivalent at 1 degree, we notice immediately that the value V_{EF} becomes equal to 0.1142 V instead of 0.15097 V in the case of fault N_0 22.

4. Conclusion

As we study the schematic of the relay, we discover that the function of the relay is based on applications of operational amplifiers, logic gates, resistor bridges, rectifier bridges. In order to facilitate understanding of functioning of relay, we have established mathematical expressions relatively comprehensible. Although the relay RM3-TR113QN7 have been made in order to ensure protection against 3-phase 400VAC power supply faults, however it presents some deficiencies consisting in the non-detection of events as follows : Overvoltage more than 10% on L_1 , overvoltage more than 10% on L_1 and L_2 and Under voltage more than 10% on L_2 and L_3 . The study of the schematic of the relay permits us to give explanations on the way the 3-phase power supply is detected. Mathematical expressions we establish permit us to give

explanations of the deficiency of relay according to the three events that the relay doesn't monitor, these cases compared with all 24 possible events. This work reveals that:

For a 3-phase power supply in normal conditions $U_n=230$ V; rotational order of phases: $L_1 \rightarrow L_2 \rightarrow L_3$, the value V_{ABave} is 0.21317 V, the value of V_{EFave} is 0.155245 V.

The normal state of the 3-phase power supply is represented by the value of V_{EF} such as: $0.140 \text{ volts} < V_{EF} < 0.170 \text{ volts}$. For others abnormal events the voltage V_{EF} have a value non included in this *interval*. Reference voltages for detection are:

0.140 Volt for detection of under voltage faults, 0.170 V for detection of overvoltage faults, and 2.558 V for detection of phase failure or abnormal rotational order of phases. The mathematical aspect of functioning of relay explains how the relay operates in cases of phase failure, abnormal rotational order of phases, under voltage, and overvoltage.

Results given show that:

- In case of under voltage on all phases, we have $V_{EFave} = 0.139$ V, this is less than à 0.140 V.
- In case of overvoltage on all phases, we have $V_{EFave} = 0.170769$ V.
- In case of phase failure or abnormal rotational order of phases, the voltage $V_{EFave} = 0.289$ V and this is more than 2.558 V, then it ensure the switching of relay.

This work opens a door to future research, and in the near future we will try to resolve the inadequacies of the relay studied in this work.

References

- Ahmad FA, Azah M, Hussain S. Intelligent detection of unstable power swing for correct distance relay operation using S-transform and neural networks. *Expert Systems with Applications* 2011; 38: 14969-14975.
- Chaitanya BK, Yadav A. An intelligent fault detection and classification scheme for distribution lines integrated with distributed generators. *Computers and Electrical Engineering* 2018; 69: 28-40.
- Deekshit KKC, Venu GRM, Srinivasa RR. Bearing fault detection in a 3 phase induction motor using stator current frequency spectral subtraction with various wavelet decomposition techniques. *Ain Shams Engineering Journal* 2018; 9: 2427-2439.

Kavaskar S, Mohanty NK. Combined Mathematical Morphology and Data Mining Based High Impedance Fault Detection. Energy Procedia 2017; 117: 417-423.

Kenneth VC. Determining the effective or RMS of various waveforms without calculus.Ph.D, School of sciences and technology. College of the Bahamas 2007.

Schneider. RM3 Specialty Relays.Squared1996.

Suryanarayana G, Kesava RG, Sarangi S, Raja P.Directionaly relaying using parameter estimation approach. Electrical Power and Energy Systems 2019; 107: 597-604.

Wang X, Song G, Gao J, Wei X, Wei Y, Mostafa K, Hu Z, Zhang Z. High impedance fault detection method based on improved complete ensemble empirical mode decomposition for DC distribution network. Electrical Power and Energy Systems 2019;107: 538-556.