

# Performance Evaluation of Smart Antenna: DOA Estimation using MUSIC and Beamforming using LMS

D. D. Khumane\* S. M. Jagade\*\*

\*Department of Electronics and Telecommunication Engineering, S.T.B. College of Engineering, Tuljapur, India,

\*\*Department of Electronics and Telecommunication Engineering, S.T.B. College of Engineering, Tuljapur, India,

\*\*\*\*\*

## Abstract:

This paper presents a simulation study of a smart antenna (SA) system based on direction-of-arrival (DOA) estimation is based on the Multiple Signal Classification (MUSIC) algorithm for finding the Position Location (PL) of the desired user. The beamformer steer the main beam towards the desired user and nullify all other interferer, through adaptive beamforming using Least Mean Square (LMS) algorithm. This simulation results revealed the sharper peaks in the MUSIC angular spectrum and deep nulls in the LMS beam pattern. Also, this paper deals with DOA estimation and adaptive beamforming for the dynamic case based on SA. Eigen decomposing fined the PL of the desired user using MUSIC algorithm and steer the beam toward this user using compute the weight vectors like Least Mean Square (LMS) algorithm. Also this paper illustrates the results for the LMS error on the basis of number of iteration / sample.

**Key words – Smart Antenna (SA), Beamformer, Direction-of-Arrival (DOA) Estimation, Multiple Single Classification (MUSIC), Least Mean Square (LMS), Signal Nulling.**

\*\*\*\*\*

## I. INTRODUCTION

There is an ever increasing demand on mobile wireless operators to provide voice and high speed data services. At the same time, these operators want to support more users per base station to reduce overall network cost and make the services affordable to subscribers. As a result, wireless systems that enable higher data rates and higher capabilities are pressing need. Unfortunately because the available broadcast spectrum is limited, attempts to increase traffic within a fixed bandwidth create more interference in the system and degrade the signal quality. When omnidirectional antennas are used at the base station, the transmission and reception of each users signal becomes a

source of interference to other users located in the same cell, making the overall system interference limited.

The demand for wireless services has risen dramatically from few years. Wireless communication systems are evolving from the second generation systems to the third and fourth generation systems, which will provide high data rate multimedia services as video transmission. New value added services such as the position location (PL) services for emerging calls, the fraud detection, intelligent transportation systems, and so fourth are also coming in to reality[1,2,3].

The smart antenna systems can generally be classified as either switched beam or adaptive array systems. In a switched beam systems can generally be classified as either switched beam or adaptive array systems. In a switched beam system multiple fixed beams in

predetermined directions are used to serve the users. In this approach the base station switches between several beams that gives the best performance as the mobile user moves through the cell. Adaptive beam forming uses antenna arrays backed by strong signal process capability to automatically change the beam pattern in accordance with the changing signal environment. It not only directs maximum radiation in the direction of the desired mobile user but also introduces nulls at interfering directions while tracking the desired mobile user at the same time. The adaptation achieved by multiplying the incoming signal with complex weights and then summing them together to obtain the desired radiation pattern. These weights are computed adaptively to adapt to the changes in the signal environment. The complex weight computation based on different criteria and incorporated in the signal processor in the form of software algorithms like Least Mean Square. [7]

A smart antenna technology can achieve a number benefits like increase the system capacity, greatly reduce interference, increase power efficiency [4, 5]. In the following section, we implement the simulation study of DOA estimation using MUSIC algorithm and adapts the beam towards the desired user and nullify all other interference signal through LMS algorithm.

## II. SYSTEM IMPLEMENTATION

The MUSIC, Multiple signal classification is a popular high resolution technique for estimating the DOA of multiple plane waves in noisy environment, using an array of multiple sensors. This algorithm involves Eigen decomposition of the covariance matrix derived from the input data model. The Eigen values of the covariance matrix are further divided into two sets called signal and noise subspaces. The signal subspace consists of vectors correspond to signals received at an array and vectors of noise subspace are completely orthogonal to the signal subspace.

This algorithm can be summarized as, Estimate the spatial covariance matrix and compute the eigenvectors in signal and noise. After computing the eigenvectors find the steering vector, incoming signal vector and noise vectors.

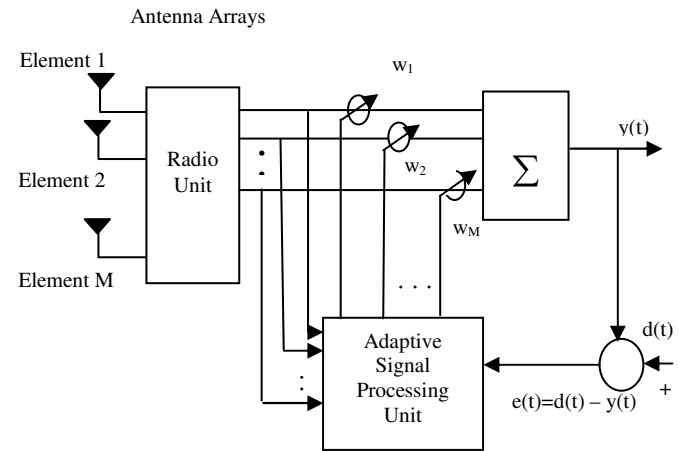

Fig.1 Smart Antenna System

Fig.1, shows the LMS adaptive beamforming network, it consist of antenna arrays, signal processing unit, radio unit and adaptive weights. Consider a Uniform Linear Array (ULA) with  $M$  isotropic elements, which forms the integral part of the adaptive beamforming system as shown in the figure above. In short, the beam forming is done digitally, the beam forming and signal processing units normally be integrated in the same unit. For the DOA estimation and beamforming the antenna array and signal processing unit etc are the common.

## III. SIMULATION AND RESULTS

As per reciprocity theory for radiation patterns, the received signals can be models as with reference to the data model equation

$$x(t) = A(\theta)s(t) + n(t) \tag{1}$$

Where,  
 $A(\theta)$  = steering vector corresponding to signal direction.

$s(t)$  = incident waves with the amplitude and phase in the azimuth plane

$n(t)$  = Additive White Gaussian Noise (AWGN)

$$x(t) = \begin{bmatrix} x_1(t) \\ x_2(t) \\ \vdots \\ x_k(t) \\ \vdots \\ x_M(t) \end{bmatrix} = \begin{bmatrix} 1 \\ \vdots \\ e^{-j2\pi/\lambda(k-1)d \sin \theta} \\ \vdots \\ e^{-j2\pi/\lambda(M-1)d \sin \theta} \end{bmatrix} * \begin{bmatrix} s_1(t) \\ \vdots \\ s_k(t) \\ \vdots \\ s_M(t) \end{bmatrix} + \begin{bmatrix} n_1(t) \\ \vdots \\ n_k(t) \\ \vdots \\ n_M(t) \end{bmatrix} \quad (2)$$

Then the signal correlation matrix at the antenna output is  $R_{xx}$

$$R_{xx} = XX^H \quad (3)$$

Where ‘X’ is the data matrix, H denotes Hermitian Transpose. The Eigenstructure method, Multiple Signal Classification (MUSIC) algorithm are implement for direction source.

In short, by using this Eigen decomposing find the Position Location of the Desire user. To implement this, MUSIC algorithm is used.

If  $S_0$  is the steering vector associated with the desired signal of interest and  $S_i$  is the steering vector associated with interfering signal then

$$WH S_0 = 1 \quad ; \text{ if user signal direction} \quad (4)$$

$$WH S_i = 0 \quad ; \text{ if interferer} \quad (5)$$

$$i = 1, 2, 3 \dots k$$

And the output of the antenna array  $x(t)$  is given by,

$$x(t) = s(t)a(\theta_0) + \sum_{i=0}^{M_u} u_i(t)a(\theta_i) + n(t) \quad (6)$$

$s(t)$  denotes the desired signal arriving at angle  $\theta_0$  and  $u_i(t)$  denotes interfering signals arriving at angle of incidences  $\theta_i$  respectively.  $a(\theta_0)$  and  $a(\theta_i)$  represent the steering vectors for the desired signal and interfering signals respectively. Therefore it is required to construct the desired

signal from the received signal amid the interfering signal and additional noise  $n(t)$

The LMS algorithm can be summarized in following equations.

$$\text{Output,} \quad y(n) = w^h x(n) \quad (7)$$

$$\text{Error,} \quad e(n) = d^*(n) - y(n) \quad (8)$$

$$\text{Weight,} \quad w(n+1) = w(n) + \mu x(n)e^*(n) \quad (9)$$

The above data model, Eigenvector decomposition for Direction of Arrival Estimation using MUSIC algorithm and the parameters/results for beamforming through LMS algorithm has been simulated on MATLAB.

For this simulation, assign a different parameters and universal constants as

Parameter	Constant to be Assigned	Value
Speed of Light	C	$3 \times 10^8$ m/s
Signal to Noise Ratio (SNR)	SNR	20dB
Number of Elements in antenna array	M	6
Number of Time Steps	N	500, 1000 & 4000
Length of Time Step	dt	$1.0000 \times 10^{-4}$
Number of Incoming Signals	L	5
Incoming Signal Frequency	$f_0$	$1 \times 10^9$ Hz
Lambda	Lambda	0.3000
Step Size	$\mu_0$	0.02

Table.1 Constants to be used for Simulation

And the simulation results on MATLAB are as:

**Case I:**

For this case we assume the five incoming signals are arriving with different angles, also here we observe the simulation for the direction and the real directions i.e. dynamic analysis. Fig. 2 shows the simulation results for DOA estimation using MUSIC algorithm and for assumptions/constants are taken as table 5.1, viz. antenna array  $M=6$ , incoming signals  $L=5$  etc. Here the predefined angles i.e. real directions for the incoming signals are 25, 80, 130, 155 degrees and the one user movement is starts at an angle of  $50^\circ$  and end at  $89.6000^\circ$  with the intervals of 0.4000 and the directions are estimated, which is given in table 2. Fig. 3 shows, all the five peaks are observed at  $25.1^\circ$ ,  $80^\circ$ ,  $87.7^\circ$ , and  $130.4^\circ$  these four peaks are very sharper, and one peak at an angle of  $157.9^\circ$  is missing.

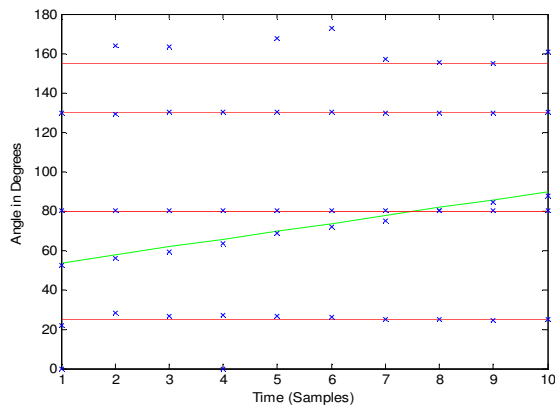

Fig. 2 Estimated Directions for Users using MUSIC Algorithm

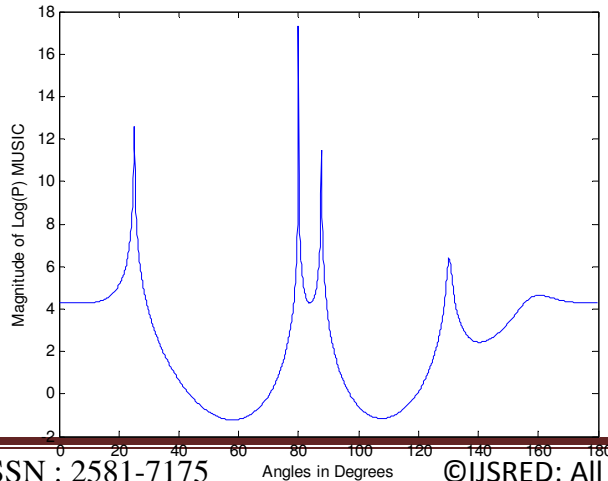

Fig. 3 MUSIC Spectrum with Five Users at Different Angles

**Case II:**

For this case we assume the five incoming signals are arriving with different angles, out of this four are coming with directions 25, 80 130 and 155 degrees and one is moved from  $50^\circ$  to  $89.600^\circ$  with the intervals of 0.400, i.e. dynamic case. And the beamformer shows the results which is shown in fig. 4 and 5. Fig. 4 shows the desired user at an angle of  $92.60^\circ$  and all other four interferer users are nullify. Also the Beamformer for the same case is shown in fig. 5.

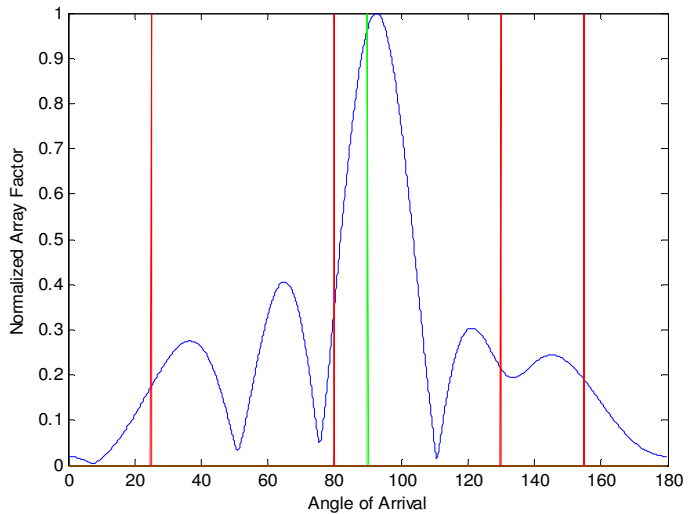

Fig. 4 Normalized Array Factor Plot for Dynamic Case

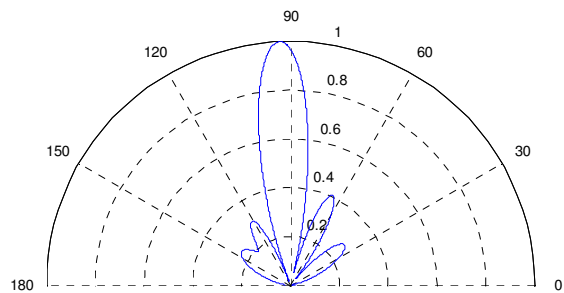

Fig. 5 Null Steering Beamformer for Dynamic Case

**Case III:**

The Fig. 6 shows the LMS error plot for the dynamic case, it shows the LMS error is almost 0.2608 at around 500 samples. The optimum complex weights in the case considered for which the algorithm converges is found to be  $W1 = 0.0774 + 0.0595i$ ,  $W2 = 0.1032 + 0.0646i$ ,  $W3 = 0.0352 + 0.0501i$ ,  $W4 = 0.0797 + 0.113i$ ,  $W5 = 0.091 + 0.0443i$ ,  $W6 = 0.099 + 0.012i$ , these are the six complex weights associated with the array elements respectively.

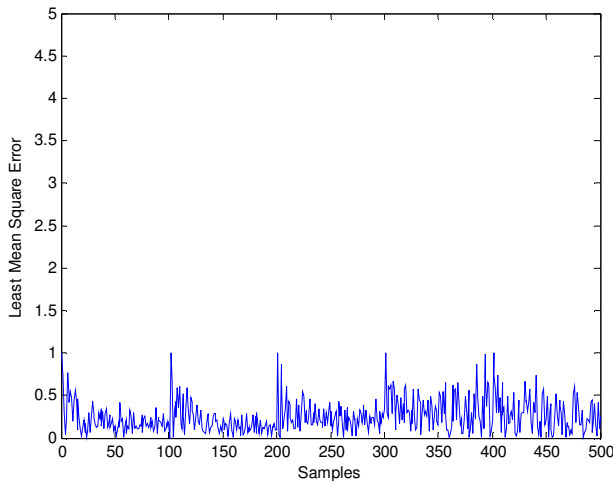

Fig. 6 LMS Error Plot for 500 Iteration

complex weights in the case considered for which the algorithm converges is found to be  $W1 = 0.1604 + 0.0533i$ ,  $W2 = 0.1052 + 0.1011i$ ,  $W3 = 0.1049 + 0.0643i$ ,  $W4 = 0.1038 - 0.0237i$ ,  $W5 = 0.1478 + 0.0542i$ ,  $W6 = 0.1495 + 0.0122i$ , these are the six complex weights associated with the array elements respectively.

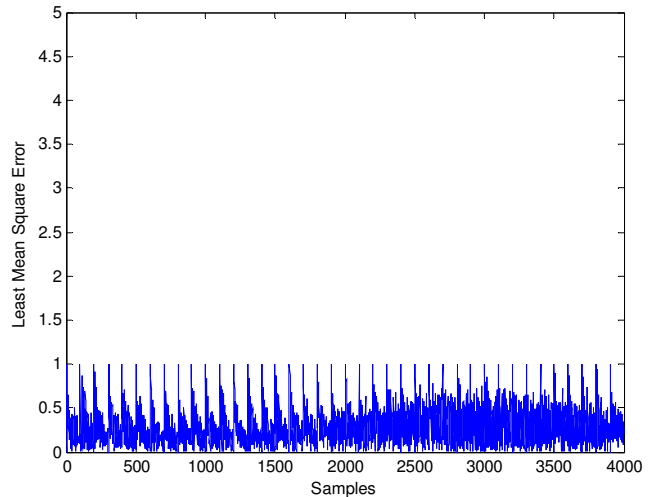

Fig. 8 LMS Error Plot for 4000 Iteration

The Fig. 8, shows the LMS error plot for the dynamic case that shows the algorithm converges. In this case the LMS error is almost 0.2075 at around 4000 iterations. And the complex weights with respect to the elements are  $W1 = 0.1804 + 0.078i$ ,  $W2 = 0.119 + 0.0872i$ ,  $W3 = 0.1051 + 0.0482i$ ,  $W4 = 0.1132 - 0.032i$ ,  $W5 = 0.1498 - 0.0898i$ ,  $W6 = 0.1613 - 0.0558i$  respectively.

#### IV. CONCLUSION

Here the simulation for the DOA estimation, compute a spatial spectrum then estimate DOA's using MUSIC algorithm. These methods apply weights to each element in the array so as to steer the antenna pattern towards a known look direction. And the capability to resolve multiple targets with separation angles smaller the main lobe beam width of the array. Once a DOA is estimated, the beamformer adapts the antenna

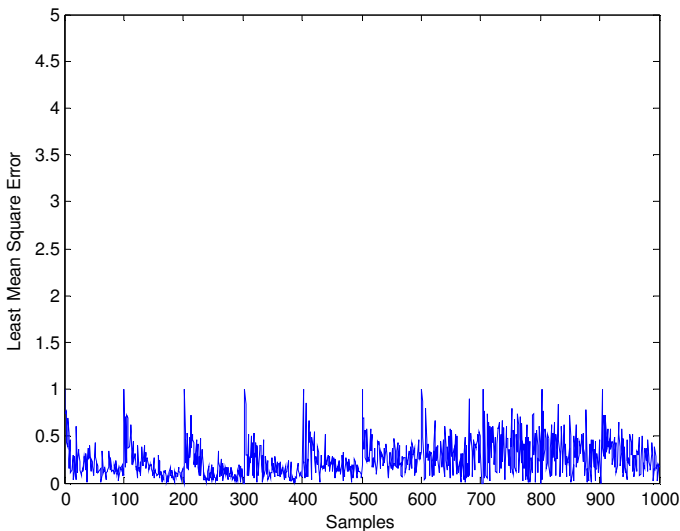

Fig. 7 LMS Error Plot for 1000 Iteration

The Fig. 7 shows the LMS error plot for the dynamic case, it shows the LMS error is almost 0.1733 at around 1000 samples. The optimum

pattern to steer the main beam towards the desired user and place nulls in the unwanted direction through LMS algorithm.

**REFERENCES**

[1] T.S. Rappaport, J.H. Reed and B.D. Woerner, "Position location using wireless communications on highways of the future," *IEEE Communications Magazine*, vol. 34, no.10, pp. 33-41, 1996.

[2] G.V. Tsoulos, "Smart antennas for mobile communication systems: benefits and challenges," *IEEE Electronic & Communication Engineering Journal*, Vol 11, no.2 pp. 84-94, 1999.

[3] K.J. Krizman, T.E. Biedka, and T.S. Rappaport, "Wireless position location: fundamentals, implementation strategies, and sources of error," in Proc. *IEEE Vehicular Technology Conference*, Vol 2 pp. 919-923, Phoenix, Ariz, USA, MAY 1997.

[4] Tsoulos G.V. Meach MA. Swalas S.C. Adaptive Antennas for Third Generation DS-CDMA Cellular Systems, *Proceedings of the 45<sup>th</sup> Vehicular Technology Conference*, Vol 1, pp. 45-49, July 1995.

[5] Okamoto G.T. Smart Antennas and Wireless LANS. Kluwer Academic Publishers, Norwell Mass., 2002

[6] Godara, L.C., Application of Antenna Arrays to Mobile Communications, Part II: Beamforming and Direction-of Arrival Considerations, *Proceedings of the IEEE*, Vol. 85, No. 8 pp 1195-1245, August 1997.

[7] Ch. Santhi Rani, P.V. Subbaiah, K. Chennakesava and S. Sudha Rani, "LMS and RLS Algorithms for Smart Antennas in a W-CDMA Mobile Communication Environment," *ARNP Journal of Engineering and Applied Sciences*" Vol. 4, no.6, August 2009.

Sample/ User	10	20	30	40	50	60	70	80	90	100
User 1	21.95	27.95	26.55	27.35	26.45	26.15	25.15	25.15	24.65	25.15
User 2	52.45	56.05	59.25	63.35	68.65	71.75	75.05	80.15	80.15	80.15
User 3	80.15	80.05	80.05	80.15	80.05	80.05	80.05	80.45	84.55	87.75
User 4	129.85	129.45	130.15	130.15	130.05	130.35	129.95	129.95	129.65	130.45
User 5	0	164.05	163.55	0	167.75	172.65	157.05	155.45	154.95	160.55

Table 2: Estimated Directions for Users