

Enhancing Automatic Generation Control of a Multi-Area Thermal System via TCPS and SMES

Bille Mokshitha, V. Surya Prakash, V.V. Gayathri

¹M.Tech scholar from the department of EEE, PVKKIT, Anantapur.

²Assistant Professor from the department of EEE, PVKKIT, Anantapur.

³Assistant Professor, from the department of EEE, PVKKIT, Anantapur.

ABSTRACT

The power systems are widely interconnected for its applicability all over the globe. Interconnection not only enhances system reliability but also improves the system efficiency. Since the system is wide and complex, for the faithful operation, the analysis of the system is of greater importance. Frequency deviations and inter-area tie-power fluctuations from scheduled values after a local load disturbance present a significant challenge in interconnected power systems. Two methods are proposed to minimize these deviations, enhancing the Automatic Generation Control (AGC) in interconnected systems. This includes integrating a Thyristor Controlled Phase Shifter (TCPS) and a Superconducting Magnetic Energy Storage (SMES) system with Fuzzy Gain Scheduling (FGS), along with a supplementary controller to improve Load Frequency Control (LFC). The current work explores the coordinated use of SMES and TCPS for AGC in a two-area interconnected thermal power system, modeled using MATLAB/SIMULINK.

INTRODUCTION

Extensive research exists on Automatic Generation Control (AGC)/LFC of single or multi-area power systems using various control strategies. The two key variables of interest are frequency and tie-line power exchanges. Their variations are combined linearly to form the Area Control Error (ACE). Over time, AGC regulator designs have evolved to address parameters such as load characteristics, excitation control, and parallel AC/DC transmission links, accommodating uncertainties and variations. Researchers continue to study different types of power plants for reliable electricity generation, including thermal, hydro, wind, solar, and nuclear sources.

However, AGC strategies often rely on linear models that may not ensure system stability due to inherent nonlinearities. Research has shown that governor dead-band nonlinearity can induce oscillations in frequency and tie-line power response, destabilizing the system. The first AGC approaches involved controlling frequency through the synchronous machine's flywheel governor, later supplemented by a signal proportional to frequency deviation and its integral.

FACTS Controllers

Advances in power electronics have led to the development of Flexible AC Transmission Systems

(FACTS), which enhance power flow control and system stability. With electricity market deregulation, the use of FACTS devices has become increasingly popular to adapt power systems to changing load and flow conditions. FACTS devices, defined as "Alternating current transmission systems combining power electronics and static controllers to improve controllability and power transfer capacity," optimize existing transmission lines.

Superconducting Magnetic Energy Storage (SMES)

SMES systems use superconducting coils to store electrical energy in a magnetic field, making it accessible when needed. SMES coils, consisting of superconductors and cooling units, store substantial power for load leveling or supplying repetitive power pulses. The cooling units are essential to maintain superconductivity in the coils. SMES systems are valuable for energy storage and power quality, offering a promising solution with various applications.

Fuzzy Logic Control

Fuzzy Logic (FL) provides a practical problem-solving method, applicable from small embedded systems to complex, multi-channel computing setups. FL can be implemented in hardware, software, or both, offering an intuitive approach to approximate conclusions based on imprecise or incomplete data. FL emulates human decision-making at high speed, making it suitable for

complex systems where traditional logical approaches fall short.

A fuzzy system processes inputs through "fuzzy sets," where values range continuously between 0 and 1. The conversion of crisp values to fuzzy values, known as "fuzzification," allows the system to apply rules that use these values to generate outputs. The control system may also include ON-OFF inputs with binary values but treats them as simplified fuzzy functions. These rules lead to a single output through "defuzzification," forming a "fuzzy expert system" that performs in a human-like manner.

Fuzzy Sets

The fuzzy control system uses "fuzzy sets," defined by membership functions, to interpret input variables. The "fuzzification" process converts crisp data to fuzzy values, which then guide the output based on applicable rules. This approach allows for an efficient decision-making process where exact mathematical models may not be available or feasible. Fuzzy control systems can be enhanced by adding new rules or integrating with existing controllers for better performance.

Conventional control systems often rely on PID controllers derived from differential equations representing system behavior. However, fuzzy logic provides an alternative where models are impractical. Additionally, FL systems are cost-effective, using simple sensors, low-resolution converters, and microcontrollers. They can also be updated easily by adding rules to enhance functionality, integrating intelligence into traditional control methods. The main components of a fuzzy logic controller are shown in Fig. 5.1 and include:

1. Fuzzification interface for converting input data to linguistic values.
2. Knowledge base with a database of linguistic definitions and control rules.
3. Decision-making logic to infer fuzzy control actions.
4. Defuzzification interface that translates fuzzy control actions into precise control signals.

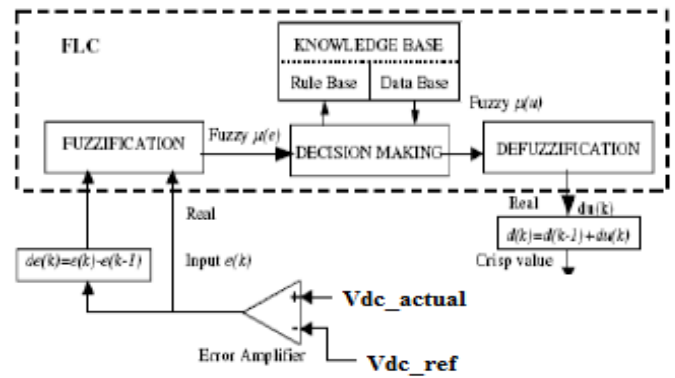

Fig. Block diagram of the Fuzzy Logic Controller (FLC) for Proposed Converter

$\Delta e \backslash e$	NL	NM	NS	EZ	PS	PM	PL
NL	NL	NL	NL	NL	NM	NS	EZ
NM	NL	NL	NL	NM	NS	EZ	PS
NS	NL	NL	NM	NS	EZ	PS	PM
EZ	NL	NM	NS	EZ	PS	PM	PL
PS	NM	NS	EZ	PS	PM	PL	PL
PM	NS	EZ	PS	PM	PL	PL	PL
PL	NL	NM	NS	EZ	PS	PM	PL

Table. Fuzzy rule table

TCPS & SMES BASED MULTI AREA THERMAL SYSTEM WITH AGC

The primary goal of Automatic Generation Control (AGC) is to maintain the balance between the electrical generator's power output and the load demand, thereby keeping the system frequency within acceptable limits despite fluctuations in system conditions and tie-line loading. This functionality, often referred to as Load Frequency Control (LFC) [1], is essential for interconnected power systems worldwide. Interconnections not only improve system reliability but also enhance overall efficiency. However, as the grid expands and integrates more utilities, managing the system becomes more complex, sometimes creating a gap between supply and demand [2]. High load on tie-lines due to power transfers can lead to poor damping, causing inter-area oscillations.

Given the unpredictability of load conditions, the complexity of system operations increases, making it a critical issue in interconnected power systems since their inception. In this context, AGC plays a vital role in ensuring stable system operations. Over recent decades, extensive research has focused on AGC in interconnected power systems [3]-[6]. Early studies proposed various strategies to improve stability under sudden demand shifts. However, due to operational constraints in thermal

power plants, many AGC solutions have yet to be widely implemented [7]. Some efforts have been made to reduce oscillations in frequency and tie-line power exchanges.

Power electronic devices, particularly Flexible AC Transmission System (FACTS) devices, have become widely accepted for enhancing control flexibility in power systems [1]. This flexibility enables independent adjustments of system parameters, such as power flows, which are not typically controllable [7]. The Thyristor-Controlled Phase Shifter (TCPS) is one such device, allowing operators to alter the phase angle between system voltages to manage real power exchanges between interconnected systems. This helps dampen oscillations in power flow following load disturbances in either area, also providing series compensation to boost stability. With rapid response capabilities, phase shifters like the TCPS are valuable for improving system stability and are effective tools for tie-line power flow control.

Typically, sudden load changes are met by the kinetic energy of the generator rotor, which aids in dampening electromechanical oscillations within the system [2]. The use of fast-acting energy storage devices can further improve transient performance by providing stored energy immediately after load disturbances. Research in [8] introduced a control approach for TCPS to dynamically regulate system frequency and dampen frequency and tie-power oscillations by controlling the TCPS phase angle. The authors in [10] investigated transient performance enhancement in hydro-based systems using SMES and TCPS controllers. This study highlighted the application of FACTS devices, specifically those with series connections, to mitigate inter-area oscillations.

The concept of using energy storage to improve system performance initially emerged in [10] and included investigations into interconnected hydro-thermal systems with capacitive storage devices and TCPS to stabilize low-frequency oscillations and enhance system transient performance. With the development of FACTS and energy storage technologies, extensive research has focused on reducing tie-line oscillations, employing devices like TCPS and Static Synchronous Series Compensators (SSSC). A review of the literature shows that most studies have treated FACTS devices and storage systems separately for frequency and tie-line power control [10-12]. However, fewer studies have examined

coordinated operation between FACTS devices and storage systems.

This thesis aims to address this gap by studying a thermal interconnected system with a Thyristor-Controlled Phase Shifter (TCPS) on the tie-line, in conjunction with a Superconducting Magnetic Energy Storage (SMES) system. The coordinated effects of TCPS and SMES on a two-area thermal system are investigated, and controllers are designed to optimize their performance.

THYRISTOR CONTROLLED PHASE SHIFTER (TCPS)

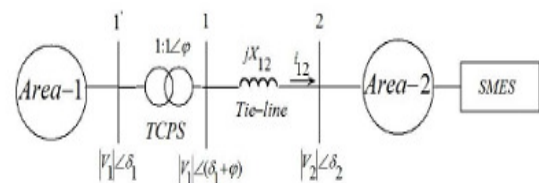

Fig. Schematic diagram of two area system with TCPS & SMES

The Thyristor-Controlled Phase Shifter (TCPS) is a device that adjusts the relative phase angle between system voltages, thereby enabling control over real power flow to reduce frequency oscillations and improve overall power system stability [7]. In this study, we consider a two-area, multi-unit thermal power system connected via a tie-line. The schematic of this interconnected system, which includes a TCPS installed in series with the tie-line, is shown in Fig. The TCPS is located near Area 1. In practical interconnected power systems, the tie-line's reactance-to-resistance ratio is typically high, meaning that the tie-line resistance has a minimal impact on dynamic performance. For this reason, the tie-line resistance is disregarded in this analysis.

SYSTEM INVESTIGATED

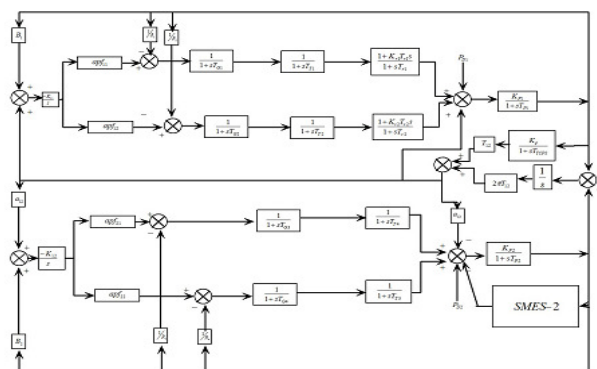

Fig. Linearized model of an interconnected thermal-thermal system

Figure shows the linearized model of an interconnected power system with Automatic Generation Control (AGC), comprising two control areas linked by a tie-line, which enables power exchange between them. Area 1 includes two reheat thermal generation units, while Area 2 consists of two non-reheat thermal generation units. Frequency stability within the power system is maintained by controlling the driving torque of the thermal turbines. The turbine in the reheat thermal units responds quickly due to the High Pressure (HP) stage, while the Low Pressure (LP) stage has a delayed response due to thermal lag. A Generation Rate Constraint (GRC) of 10% per unit MW/min for non-thermal units and 3% per unit MW/min for thermal units is applied to prevent excessive steam withdrawal from the boiler system, which could lead to condensation from rapid expansion [9, 13]. The integral gain settings for the two areas, KI1 and KI2, are the primary gain parameters for Area 1 and Area 2, respectively.

**SIMULATION RESULTS
SIMULATION DIAGRAM**

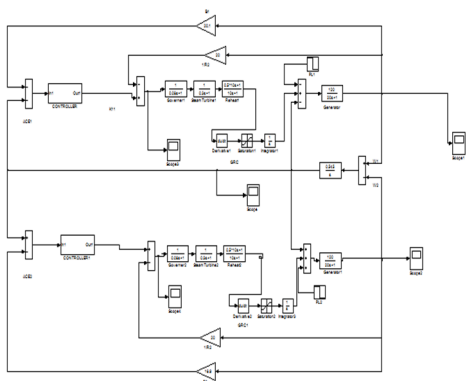
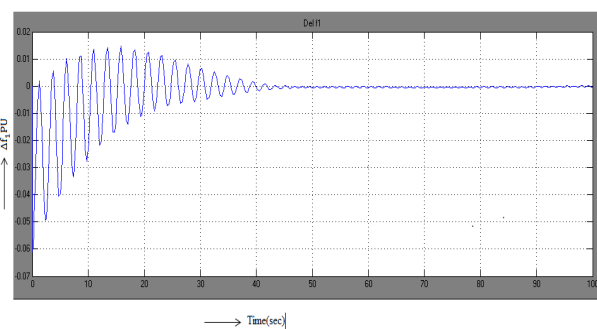
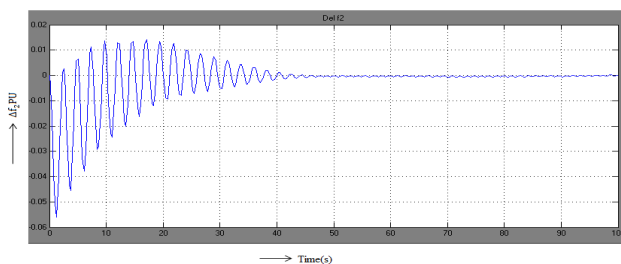

Fig. Two area thermal power system

Fig 7.1 Shows the Simulink diagram of a two area thermal power system. For a sudden load disturbance the change in frequency and change in power output and change in tie line power is shown in the following plots.



Deviation of frequency in area-1



Deviation of frequency in area-2

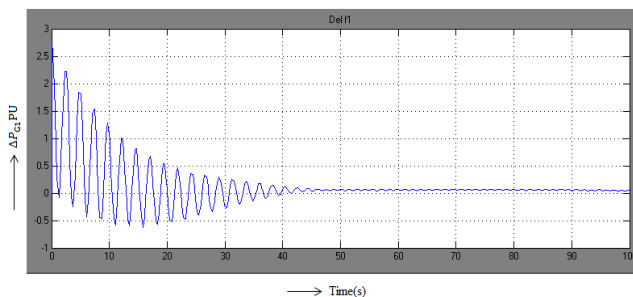

Change in power output of generator in area-1

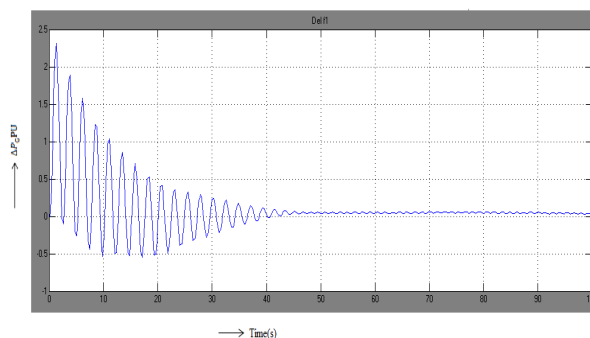

Change in power output of generator in area-2

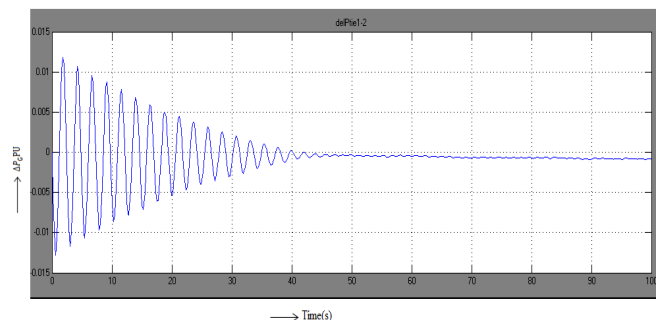

Tie-line power oscillations

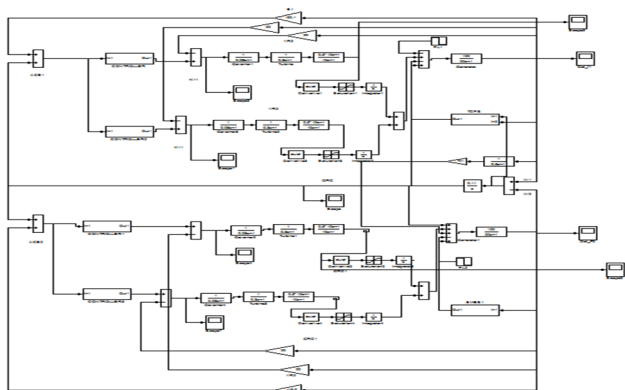

Two area thermal power system with TCPS controller in area1 and SMES Controller in area2

Fig.Shows simulink diagram of a two area thermal power system here TCPS controller are placed in area1 and SMES Controller are placed in area2.For a sudden load disturbances the change in frequency and change in power output and change in tie line power is shown in the following plots.

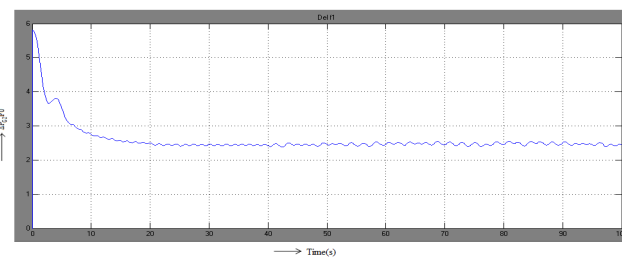

Power output of generator in area-2

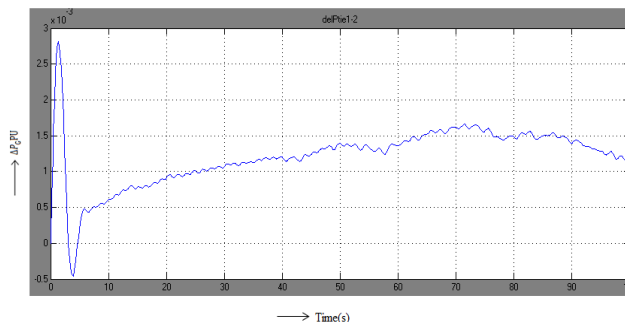

Waveform of deviation in tie-line power flow

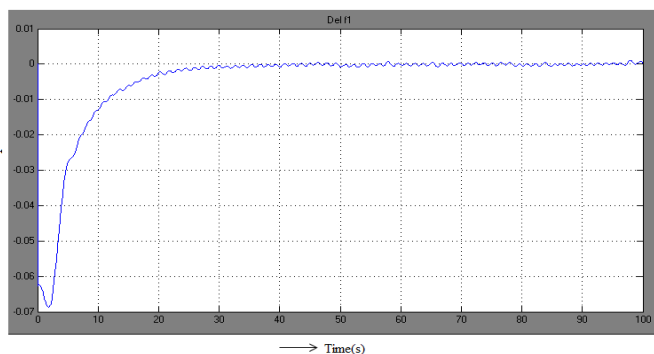

Deviation of frequency in area-1

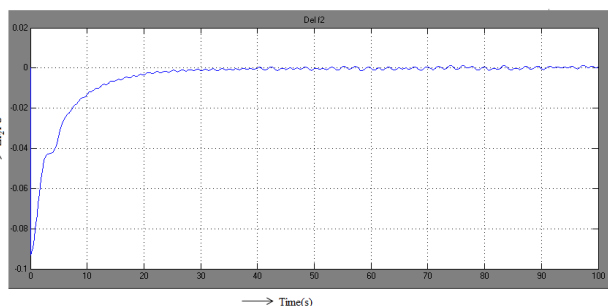

Deviation in frequency of area-2

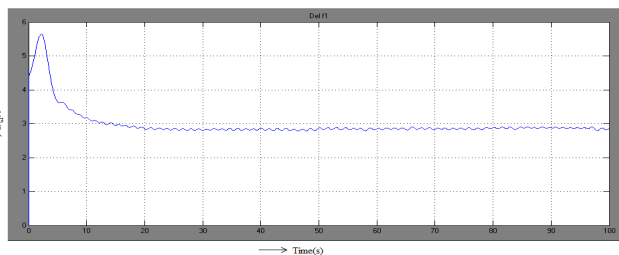

Power output of generator in area-1

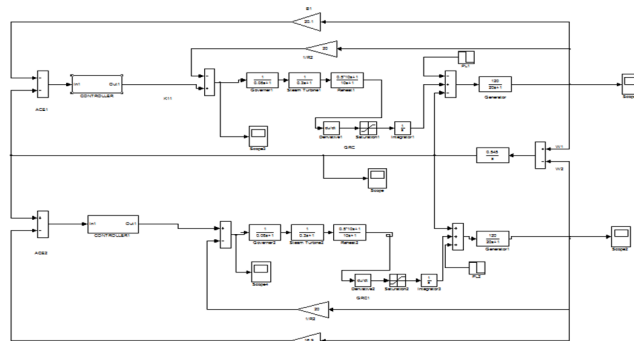

Two area thermal power system with Fuzzy controller

Fig. Shows simulink diagram of a two area thermal power system with fuzzy controller. For a sudden load disturbance the change in frequency and change in power output and change in tie line power is shown in the following plots.

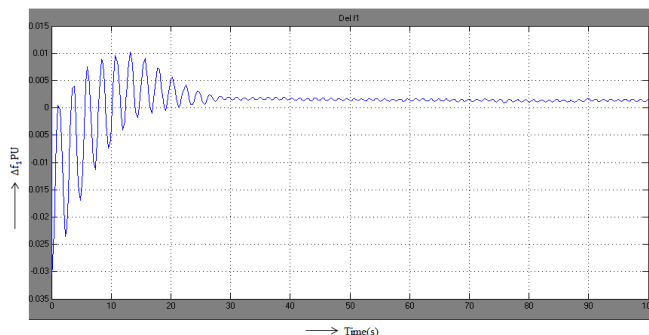

Deviation of frequency in area 1 .

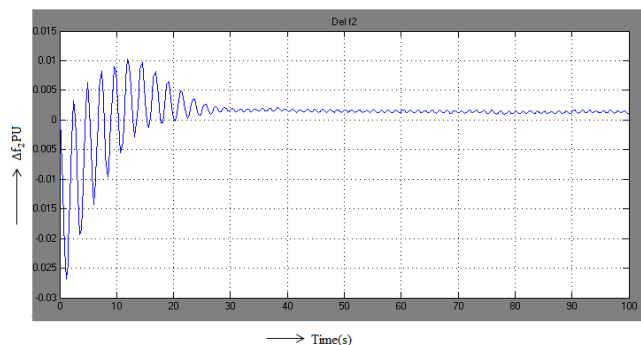

Deviation of frequency in area2

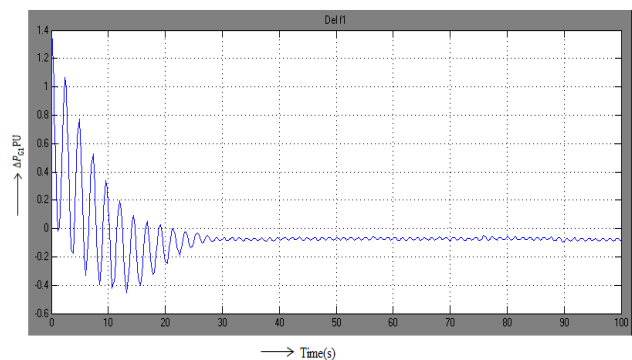

Change in power output of generator in area-1

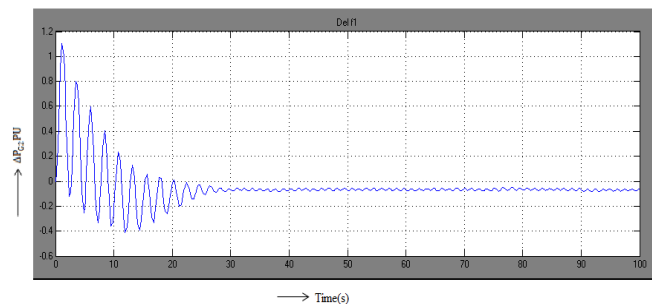

Change in power output of generator in area-2

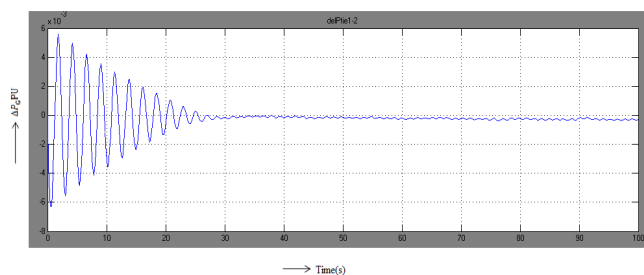

Tie-line power oscillations

Controllers	Peak undershoot			Peak overshoot		
	Δf_1	Δf_2	ΔP_{tie1}	Δf_1	Δf_2	ΔP_{tie1}
Without Controllers	-0.06	-0.055	-0.012	0.0148	0.014	0.012
With Conventional Controllers	-0.069	-0.093	-0.004	0.0012	0.001	0.008
Fuzzy Controller	-0.03	-0.027	-0.0055	0.0102	0.01	0.0055

Table: Dynamic response comparison in terms of peakundershoot (US) and peakovershoot (OS)

Controllers	ST of Δf_1	ST of Δf_2	ST of ΔP_{tie12}
Without Controllers	45	45	45
With conventional Controllers	40	40	40
Fuzzy Controller	30	30	30

Table: Dynamic response comparison in terms of settling time (ST)

It is observed that incorporation of SMES and TCPS units with PI controller in reheat thermal system reduces settling time greatly. As compared to TCPS unit, use of SMES unit reduces overshoot further with almost the same settling time. Instead of PI controller when FLC is used overshoot and undershoot decrease further.

CONCLUSION

PI controller is implemented as controller in each area of an interconnected power system with reheat type steam turbines for the cases with and without SMES units. The positive effects of SMES units on the dynamic response of AGC of two-area power system have been demonstrated. Simulation studies have been carried out using MATLAB platform to study the transient behaviors

of the frequency of each area and tie-line power deviations due to load perturbations in one of the areas.

Further, the performance of conventional integral controller (PI) and fuzzy logic controller (FLC) in a reheat thermal system has been investigated. These controllers are designed to improve the transient performance of the interconnected systems following a disturbance in the areas. Effectiveness of the proposed controller in increasing the damping of local and inter area modes of oscillation is demonstrated in a two area interconnected power system. The dynamic system responses have been examined considering a 1% step load perturbation in either area. Also the simulation results are compared with a conventional PI controller. It is observed that incorporation of SMES and TCPS units with PI controller in reheat thermal system reduces settling time greatly. As compared to TCPS unit, use of SMES unit reduces overshoot further with almost the same settling time. Instead of PI controller when FLC is used overshoot and undershoot decrease further. Settling time also improves to some extent when TCPS and SMES units are added to the FLC. The result shows that the proposed intelligent controller is having improved dynamic response and at the same time is faster than conventional PI controller.

REFERENCES

1. P. Kundur, Power System Stability and Control, McGraw-Hill Inc., New York, 1994.
2. Olle. L.Elegerd, Electric Energy systems Theory-An introduction Second Edition Tata McGraw-Hill Education Private Ltd. New Delhi, 1983.
3. Elgerd, O.I., and Fosha, C.: Optimum megawatt frequency control of multi-area electric energy systems, IEEE Trans. Power Appar. Syst., pp. 556-563,1970.
4. Cohn, N.: Techniques for improving the control of bulk power transfers on interconnected systems, IEEE Trans. Power Appar. Syst., pp. 2409- 2419,1971.
5. Miniesy, S.M., and Bohn, E.V.: Two level control of interconnected power plants, IEEE Trans. Power Appar. Syst., , pp. 2742 -2748, 1971, 90, (6)
6. Hiyama, T.: Design of decentralized load frequency regulators for interconnected power systems, IEE Proc., Gener. Transm. Distrib. 1982.

AUTHORS:

1. BILLE MOKSHITHA,

M.Tech scholar from the department of EEE, PVKKIT, Anantapur.

2.V. SURYA PRAKASH,

Assistant Professor from the department of EEE, PVKKIT, Anantapur.

3. V. V. GAYATHRI

Assistant Professor, from the department of EEE, PVKKIT, Anantapur.